

## ARS-09 & 09S Triaxial MHD Angular Rate Sensor Arrays

The triaxial kit includes three ARS-09 or ARS-09S sensors and a triaxial mounting block, which becomes a 6 degree-of-freedom measurement system with 3 optional linear accelerometers added to its mounting surfaces. The type of linear accelerometers to be mounted must be specified at time of order to ensure correct mounting holes are included in the triaxial mount.

*Custom scale factors and ranges are available.*

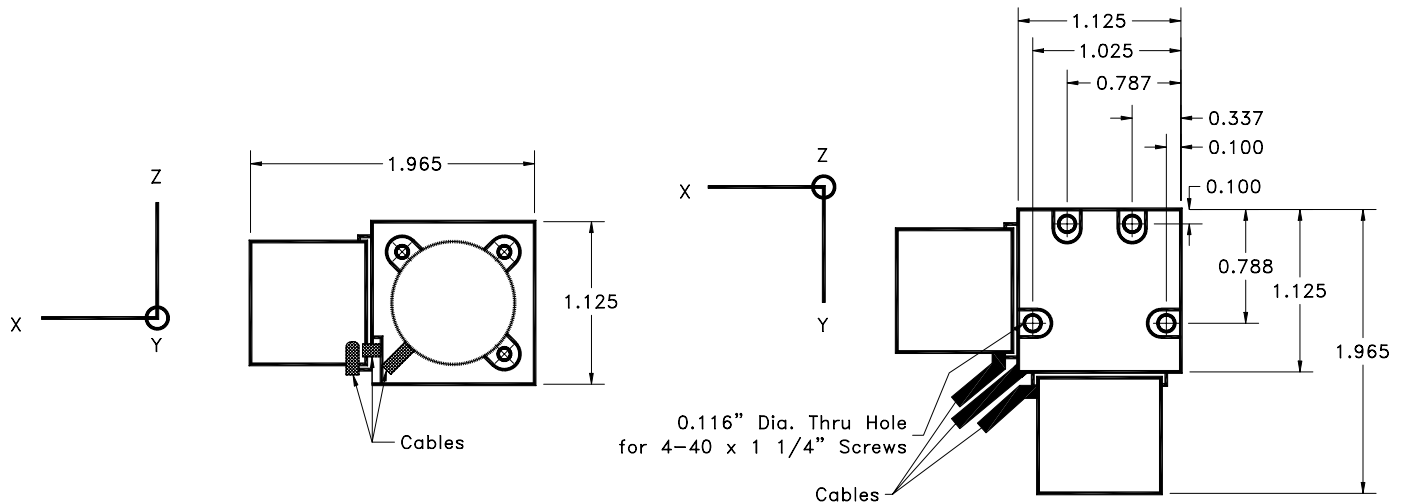
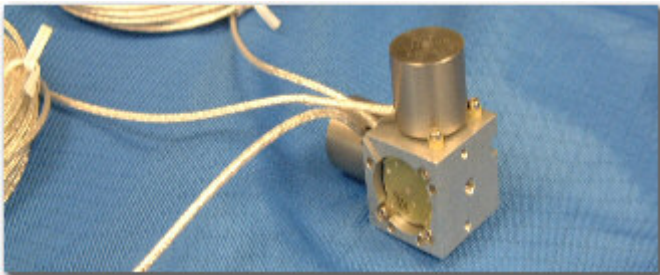

---

## Specifications

---

# ARS-09 & 09S Triaxial MHD Angular Rate Sensor Arrays

---

### Dynamic

---

ARS-09 Range <sup>1</sup>	$\pm 1.75$ radian/sec ( $\pm 100$ degree/sec)
ARS-09S Range <sup>2</sup>	$\pm 0.60$ radian/sec ( $\pm 35$ degree/sec)
Scale Factor <sup>3</sup>	5700 mV/radian/sec (100 mV/degree/sec)
Bandwidth <sup>4</sup>	0.3 to 1000 Hz
Cross-axis Angular Error	< 2 %
Linear Acceleration Sensitivity	< 0.009 radians/sec/g (<0.5 degrees/sec/g)
Voltage Noise PSD <sup>5</sup>	$1.1 \times 10^{-6}$ V <sup>2</sup> /Hz
Noise Equivalent Angle	< 80 microradians (rms)
Noise Equivalent Rate	< 8 milliradians/s (rms)
Non-linearity	< 0.1 %
Temperature Coefficient <sup>6</sup>	< 0.1 % Scale Factor / °C

---

### Electrical

---

Power Dissipation	< 0.3 Watts
Output Impedance	< 100 Ohms
Grounding <sup>7</sup>	Mounting flange isolated from signal return

---

### Wiring

---

ARS-09		ARS-09S	
Red Lead	+Power (+5 Vdc to +15 Vdc)	Red Lead	+Power (+10 Vdc)
White Lead	-Power (-5 Vdc to -15 Vdc)	White Lead	-Power (0 Vdc)
Yellow Lead	Signal	Yellow Lead	Signal
Black Lead	Power and Signal Common (0 Vdc)	Black Lead	Signal Common (+5 Vdc, internally generated reference voltage)

---

### Environmental

---

Temperature - operating	-35 to +60 °C (-31 to +140 °F)
Temperature - Non-operating	-35 to +60 °C (-31 to +140 °F)
Linear Acceleration <sup>8</sup> , Max. Operating	200 g any axis
Linear Acceleration <sup>8</sup> , Max. Survivable	200 g any axis

---

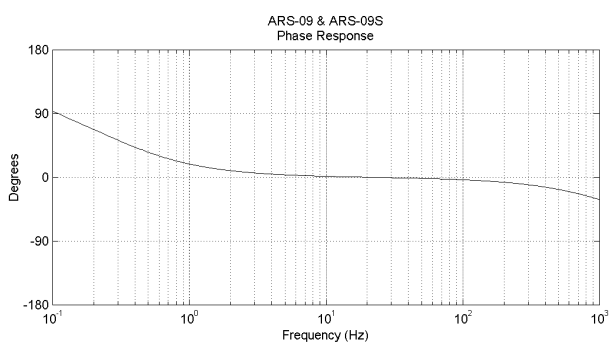
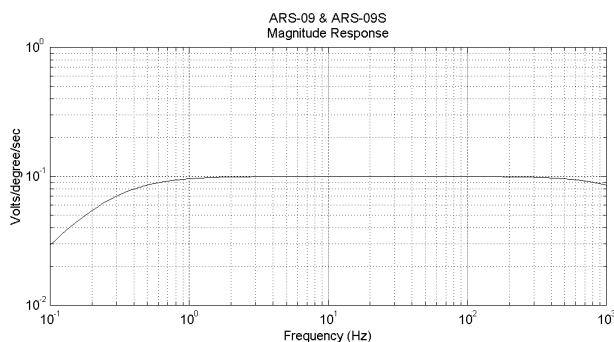

#### Notes:

1. Based on a  $\pm 10$ V output voltage swing.
2. Based on a  $\pm 3.5$ V output voltage swing.
3. Measured @ 10 Hz.
4. The standard frequency response of MHD sensors can be extended significantly by the use of digital filtering in post processing of signal data as covered in ATA Sensors' application note AN-01.
5. Power spectral density flat to angular velocity over specified bandwidth.
6. Percent change in Scale Factor per °C @ 100 Hz.
7. Signal return connected to case (isolated from mounting flange). Do not ground case to mounting fixture to avoid ground loops.
8. Peak, 100 Hz half sine.